

flatpack footbridge  
April 2026

minimass<sup>TM</sup>

from  
**600**  
£ / sqm

from  
**100**  
kg CO2e / sqm

only  
**1**  
day install

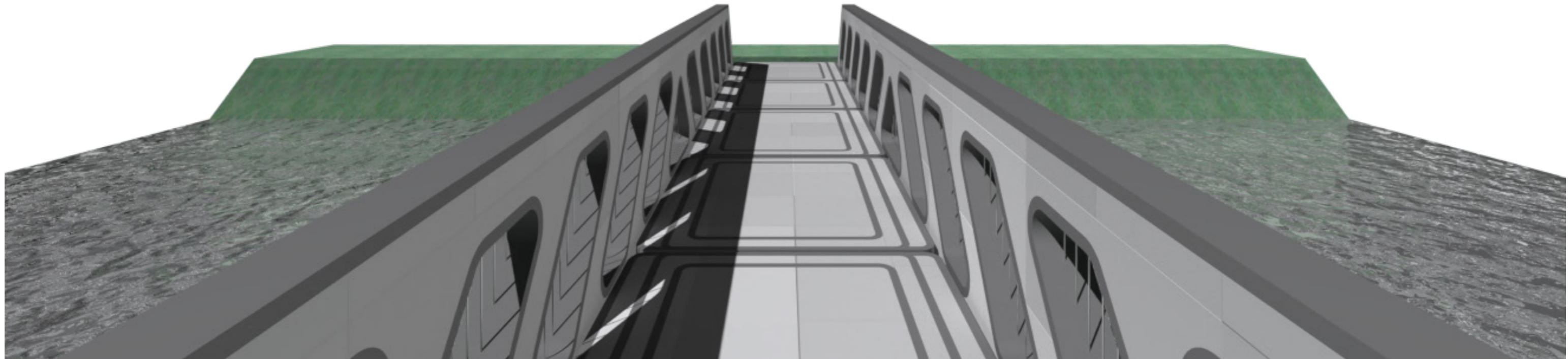

### The flatpack footbridge:

- is a pre-designed, modular bridge solution
- is designed for footbridges and cycle bridges
- has either 50 yr or 100 yr design life
- spans between 6m (shortest) and 14m (longest)
- is either 2 m clear width or 3 m clear width
- is delivered to site on the back of a flatbed trailer
- integrates the parapet, with no need for additional handrails

### Why you should use the flatpack footbridge:

- very low cost
- very low embodied carbon
- very fast to install (1 day), using only bolted connections
- very low maintenance
- very easy to specify: choose span, width and foot or cycle type

6 m span  
(shortest)

elevation

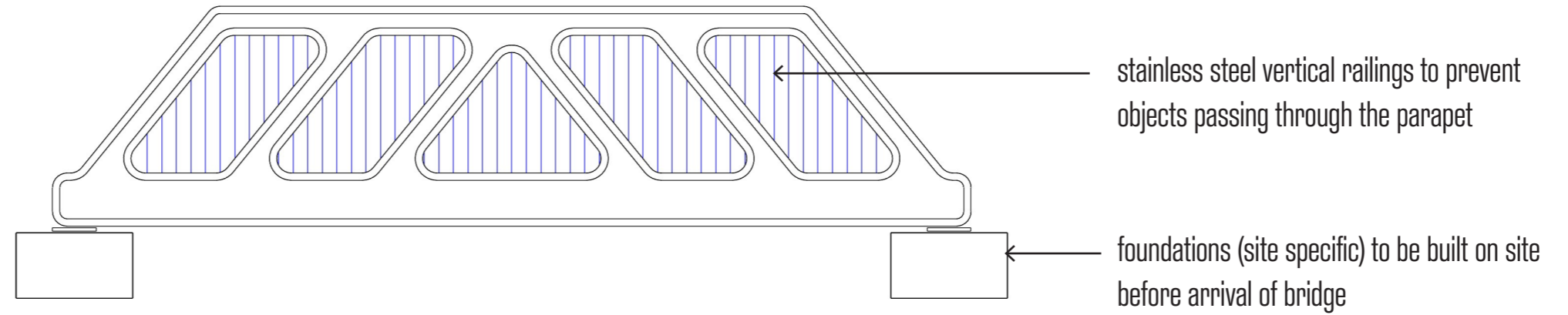

plan

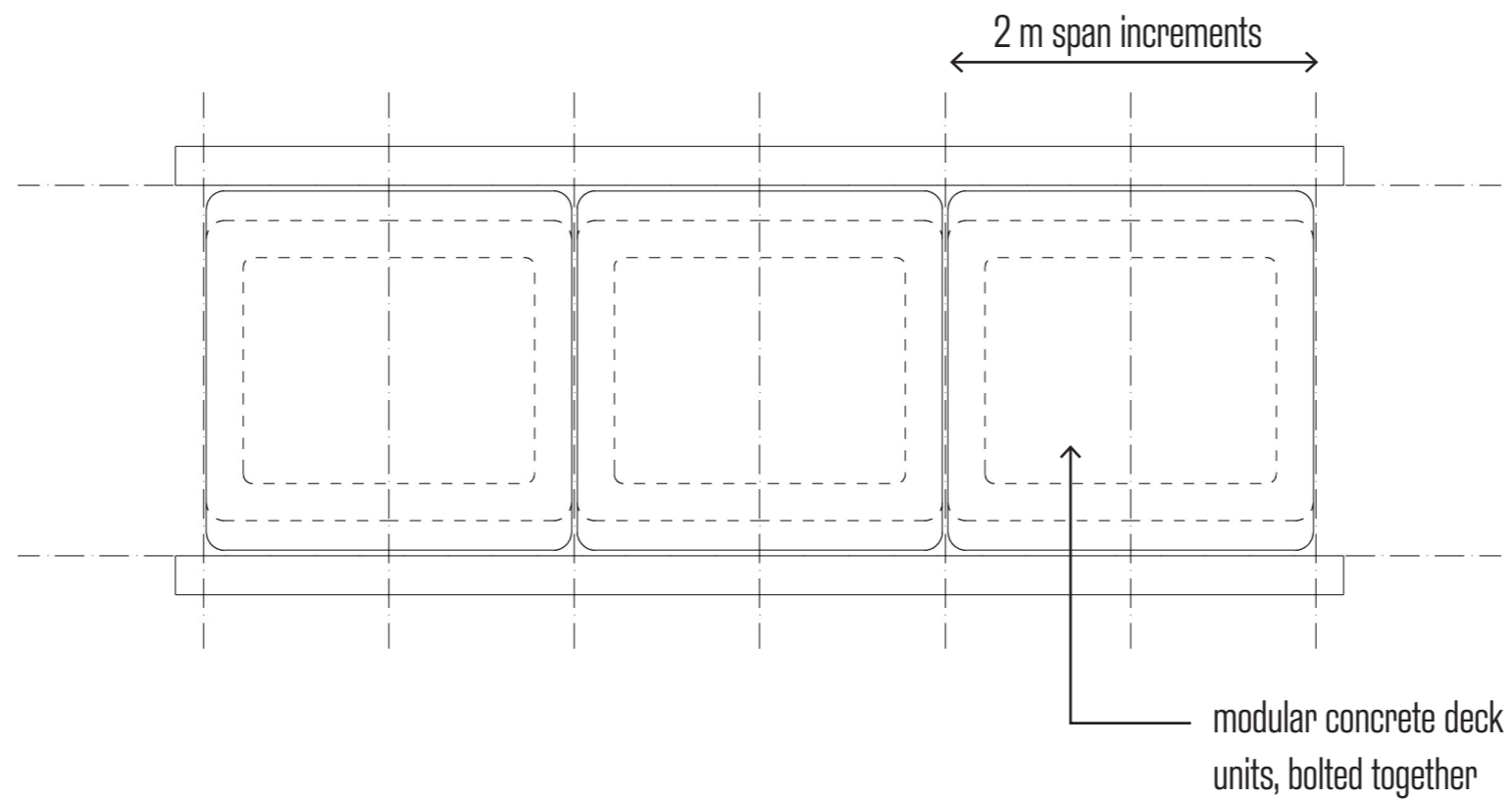

section

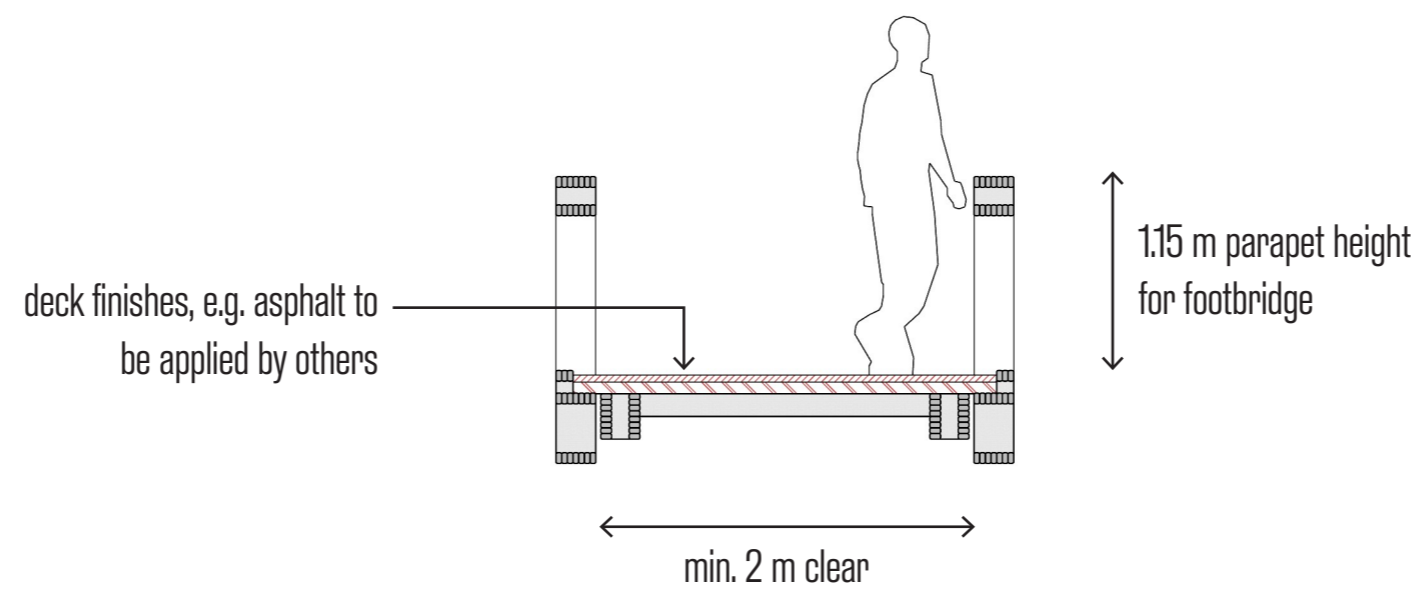

minimass™

14 m span  
(longest)

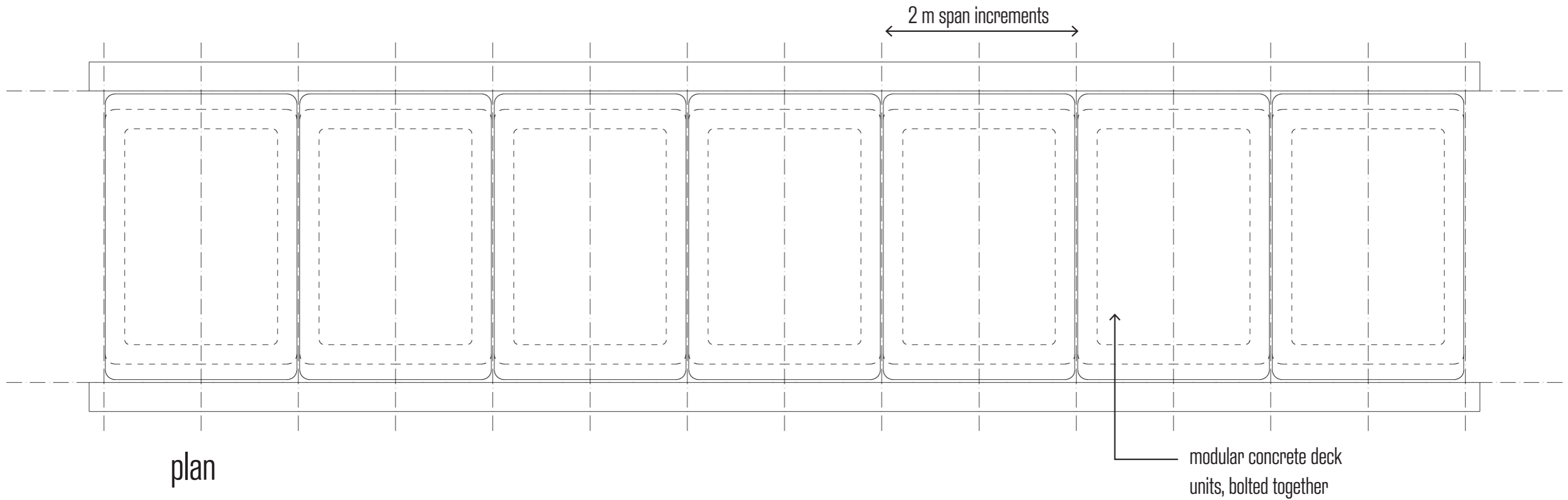
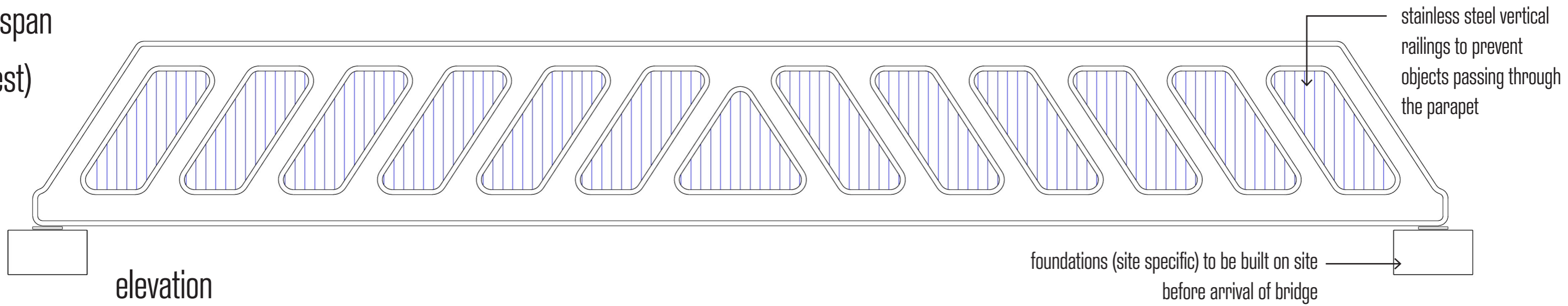

section

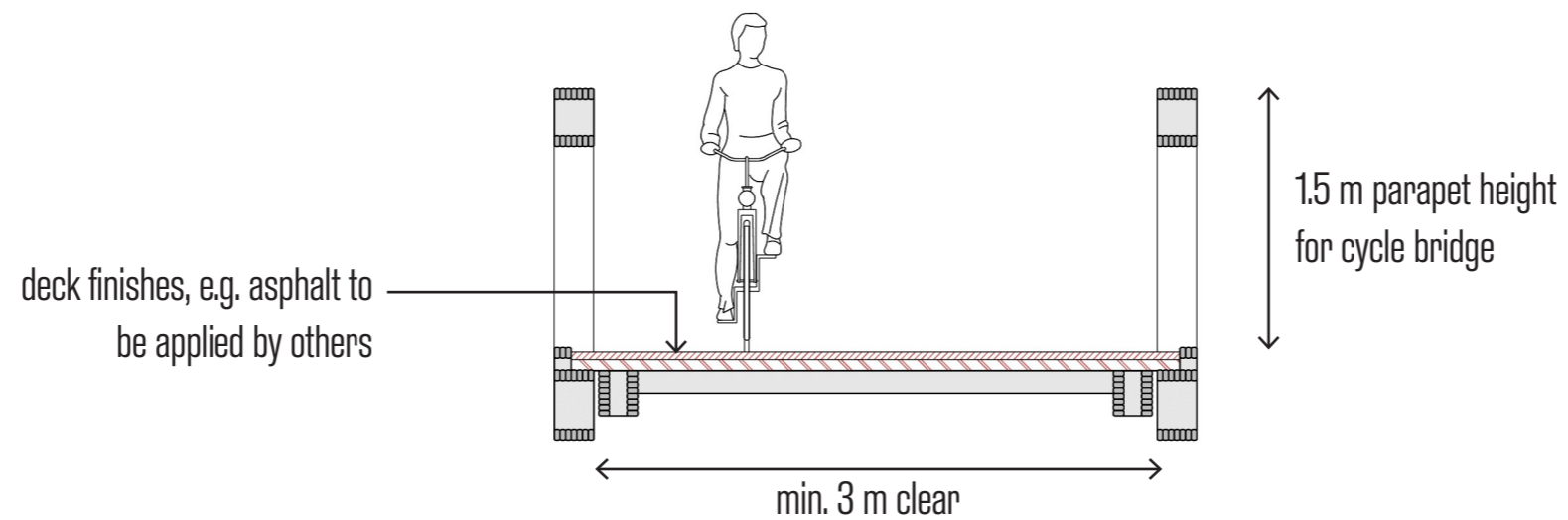

minimass™

[get in touch to find out more](#)

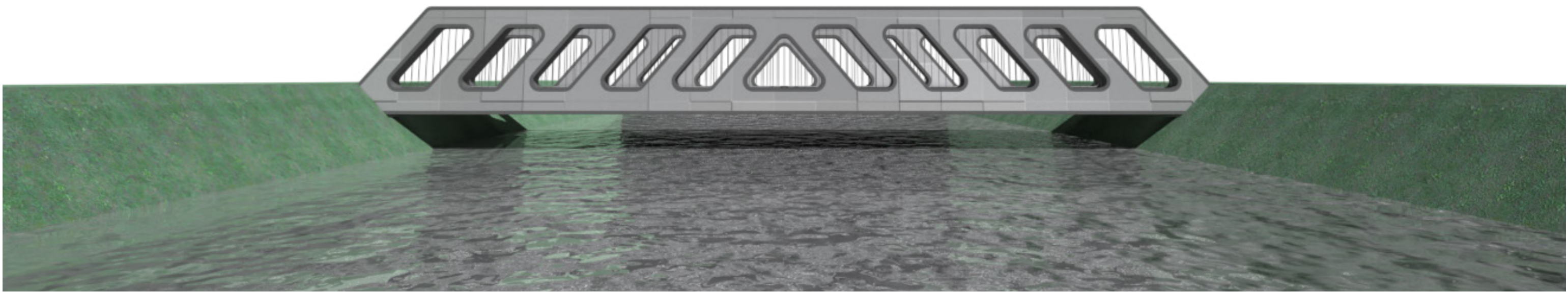

## Construction sequence

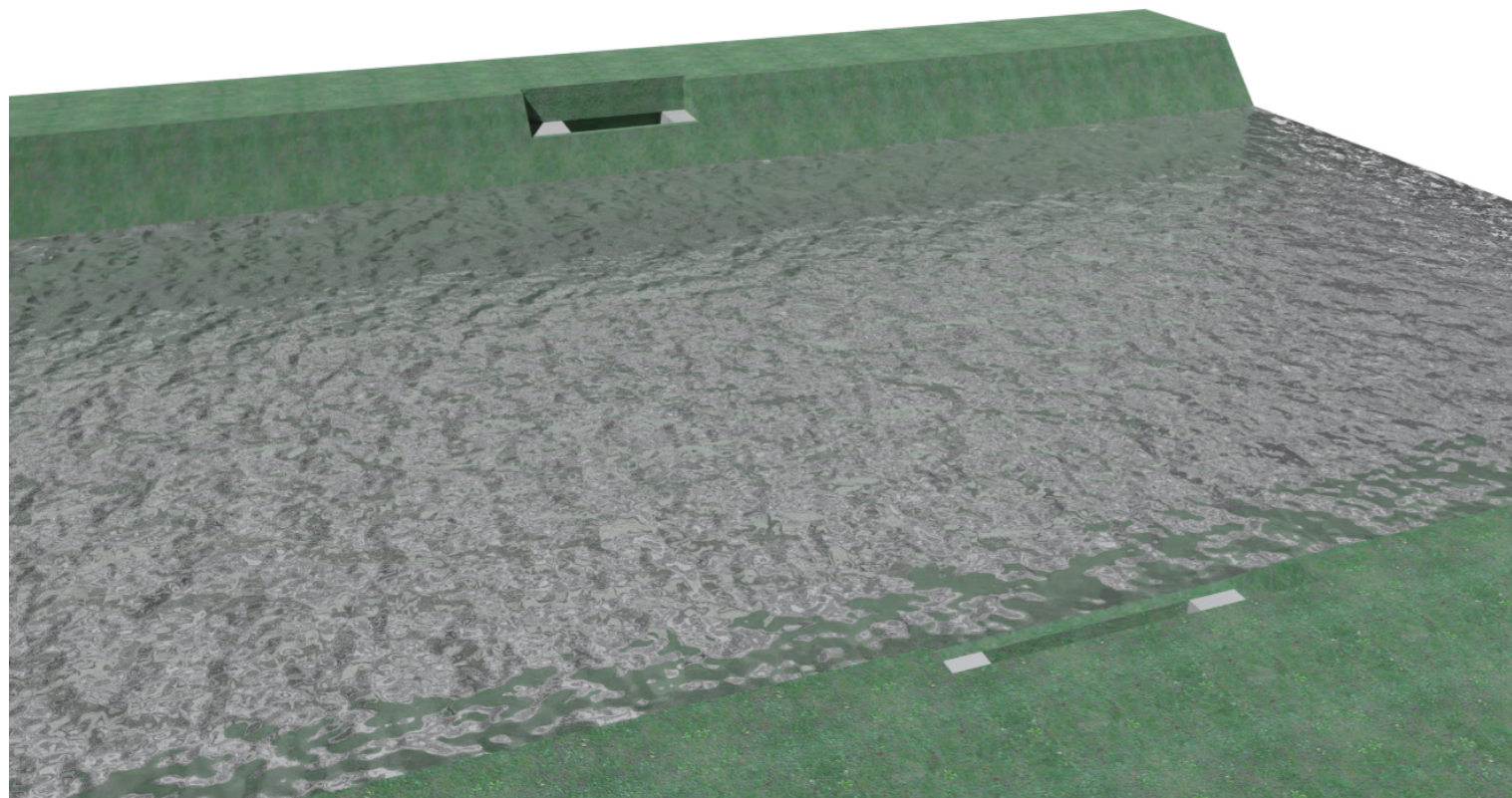

### step 1: foundations

This is site specific and needs to be completed before the minimass bridge arrives on site.

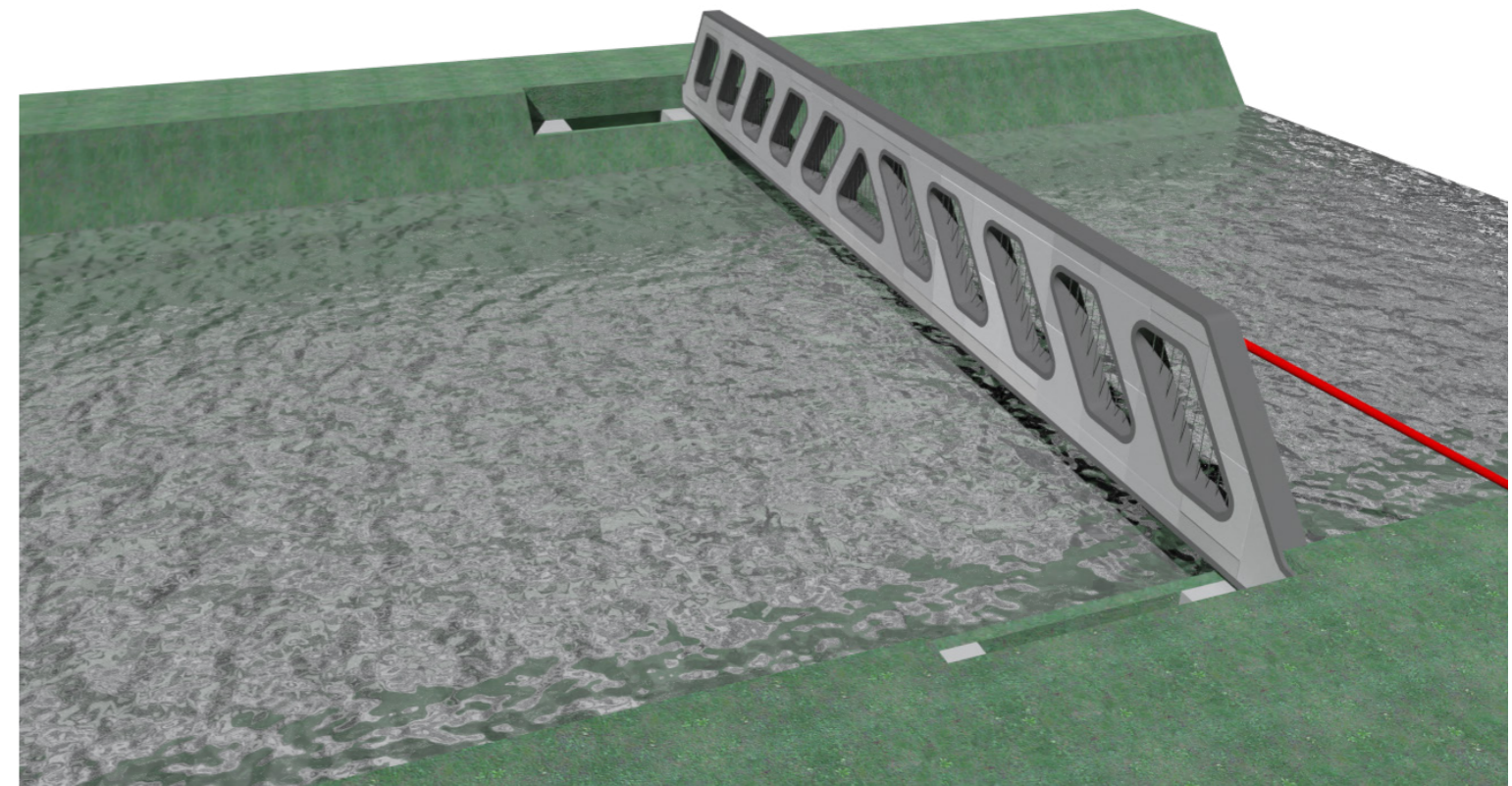

### step 2: truss no. 1

The first truss is craned directly off the delivery trailer and into position. Diagonal temporary props are installed at each bank to prevent the truss from rotating sideways during construction.

## Construction sequence

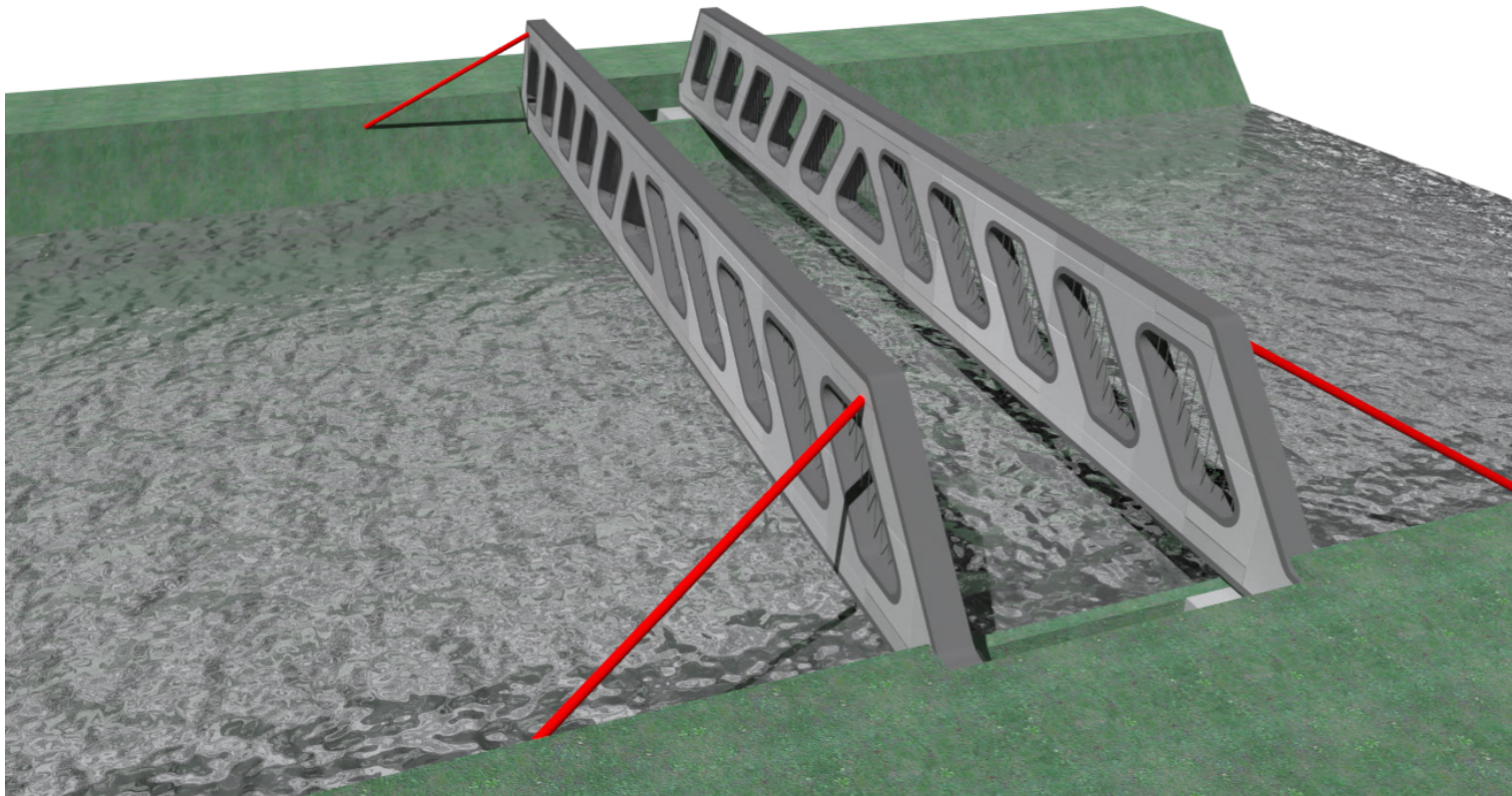

### step 3: truss no. 2

The second truss is craned directly off the delivery trailer and into position. Diagonal temporary props are installed at each bank.

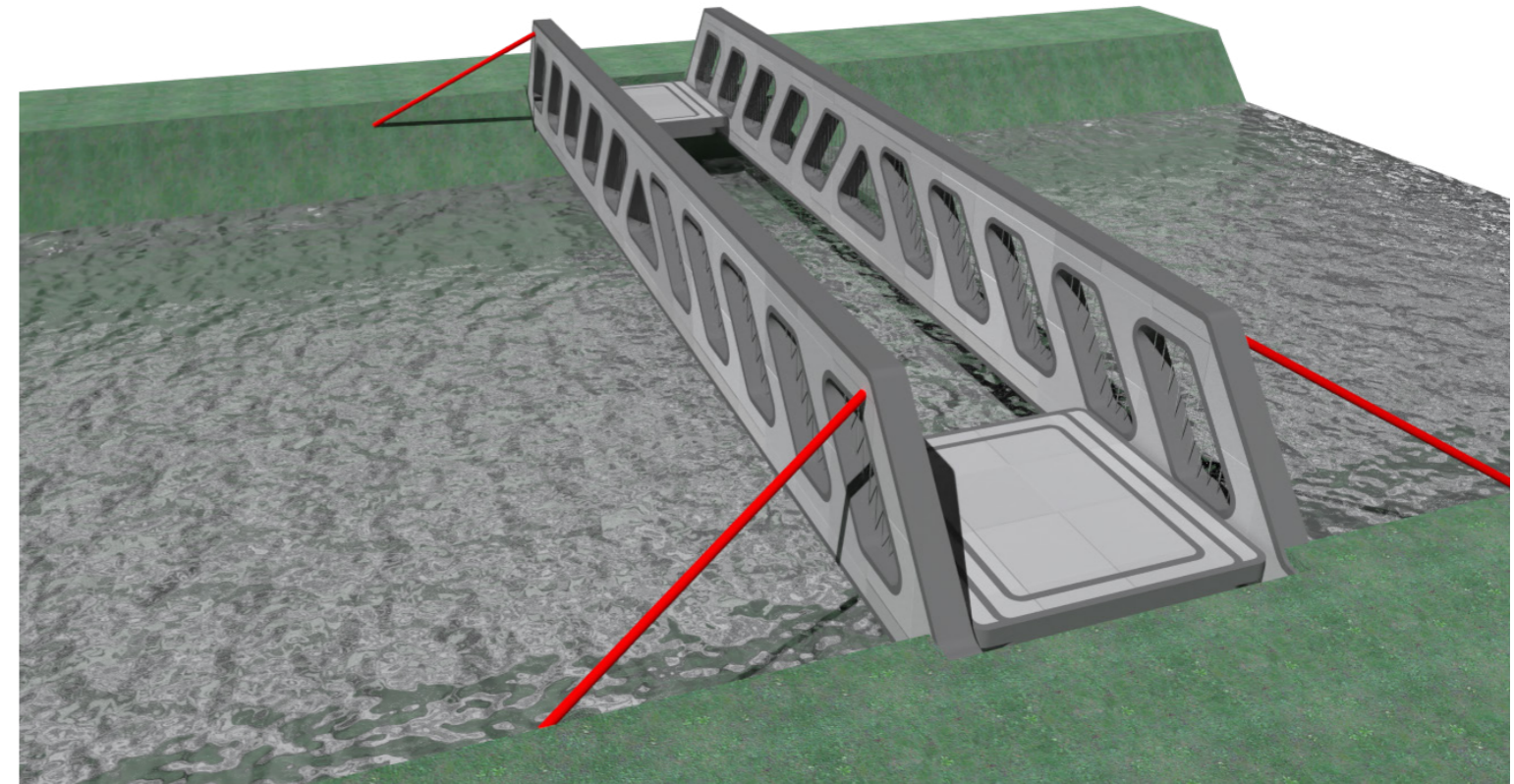

### step 4: slabs

The slab pieces are installed next, craned directly from the delivery trailer. Slabs are positioned from the ends first, working towards the centre. Bolted connections secure them in place.

## Construction sequence

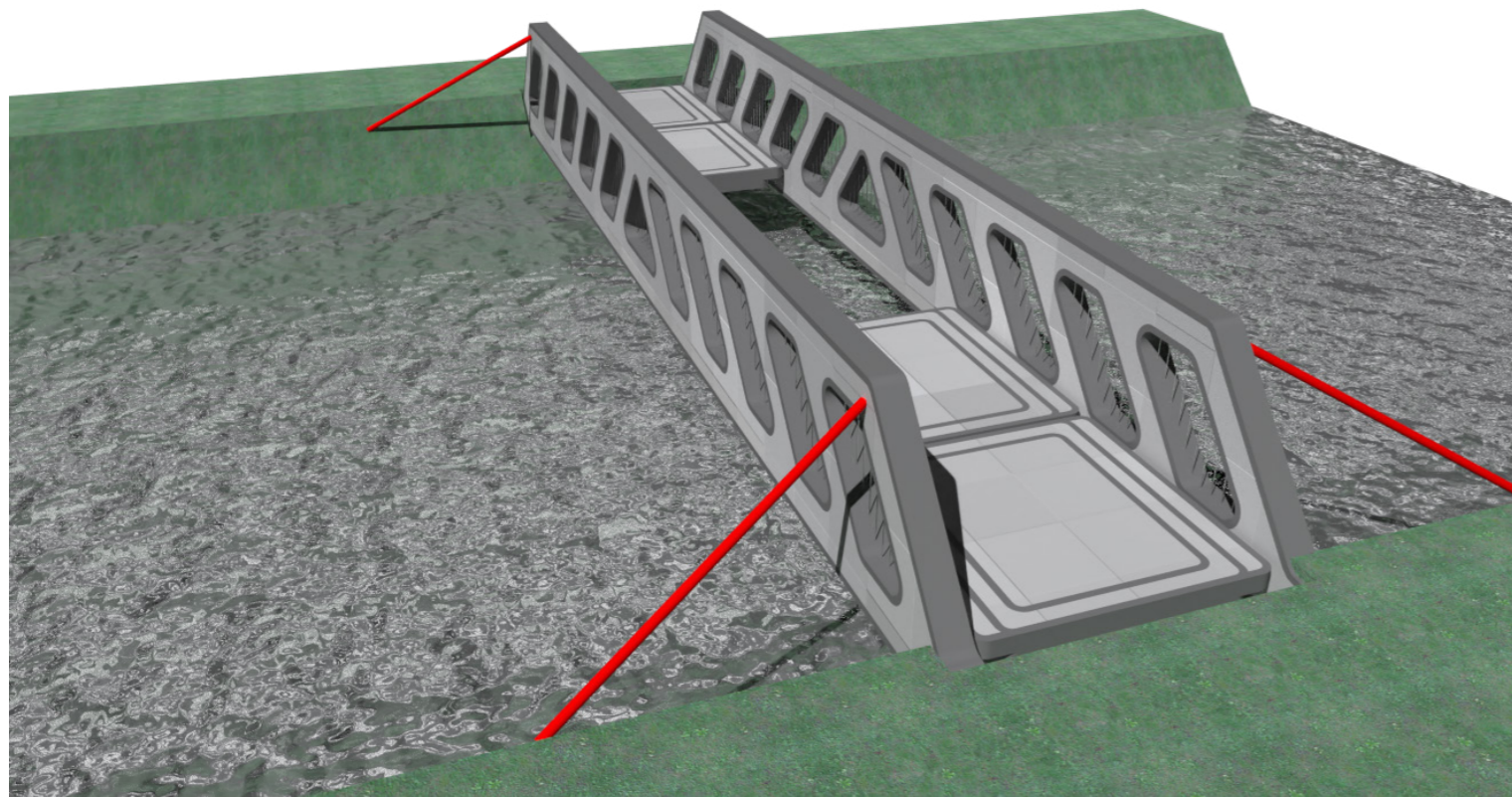

### step 5: slabs

The second pair of slab units are picked, placed and bolted into position.

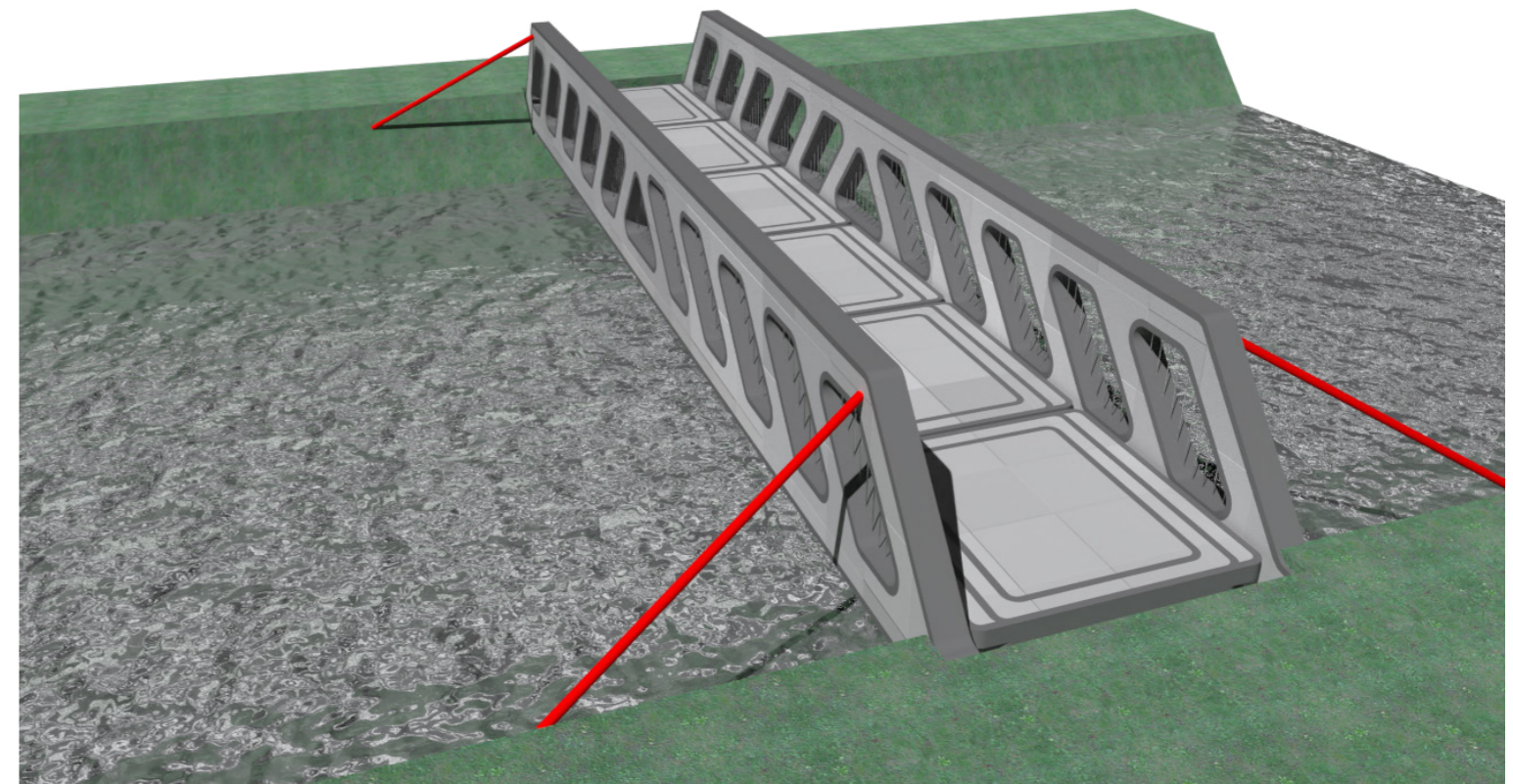

### step 6: slabs

The last pair of slab units are picked, placed and bolted into position.

## Construction sequence

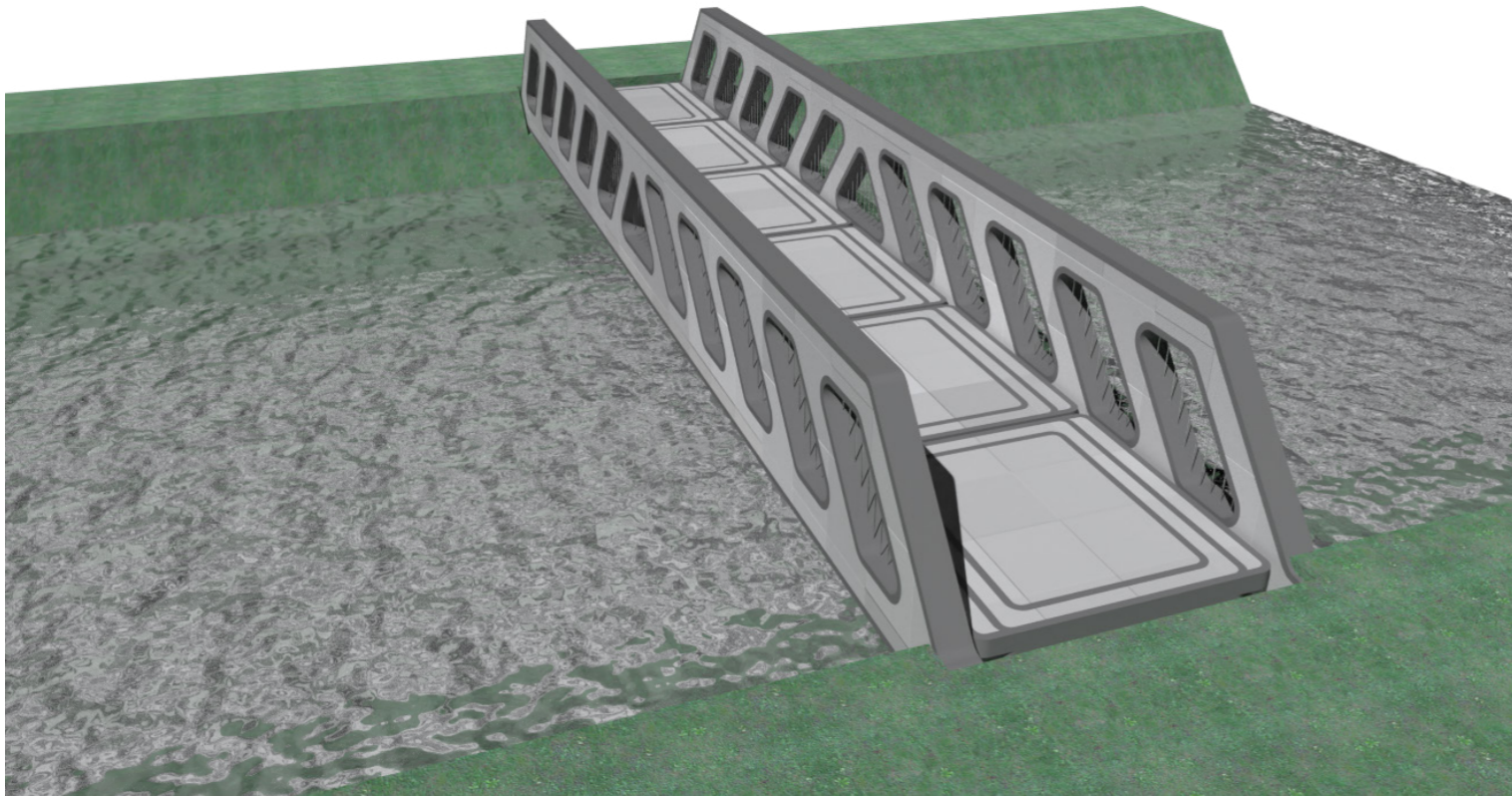

### step 7: structural completion

The temporary props are removed and the bridge is structurally complete.

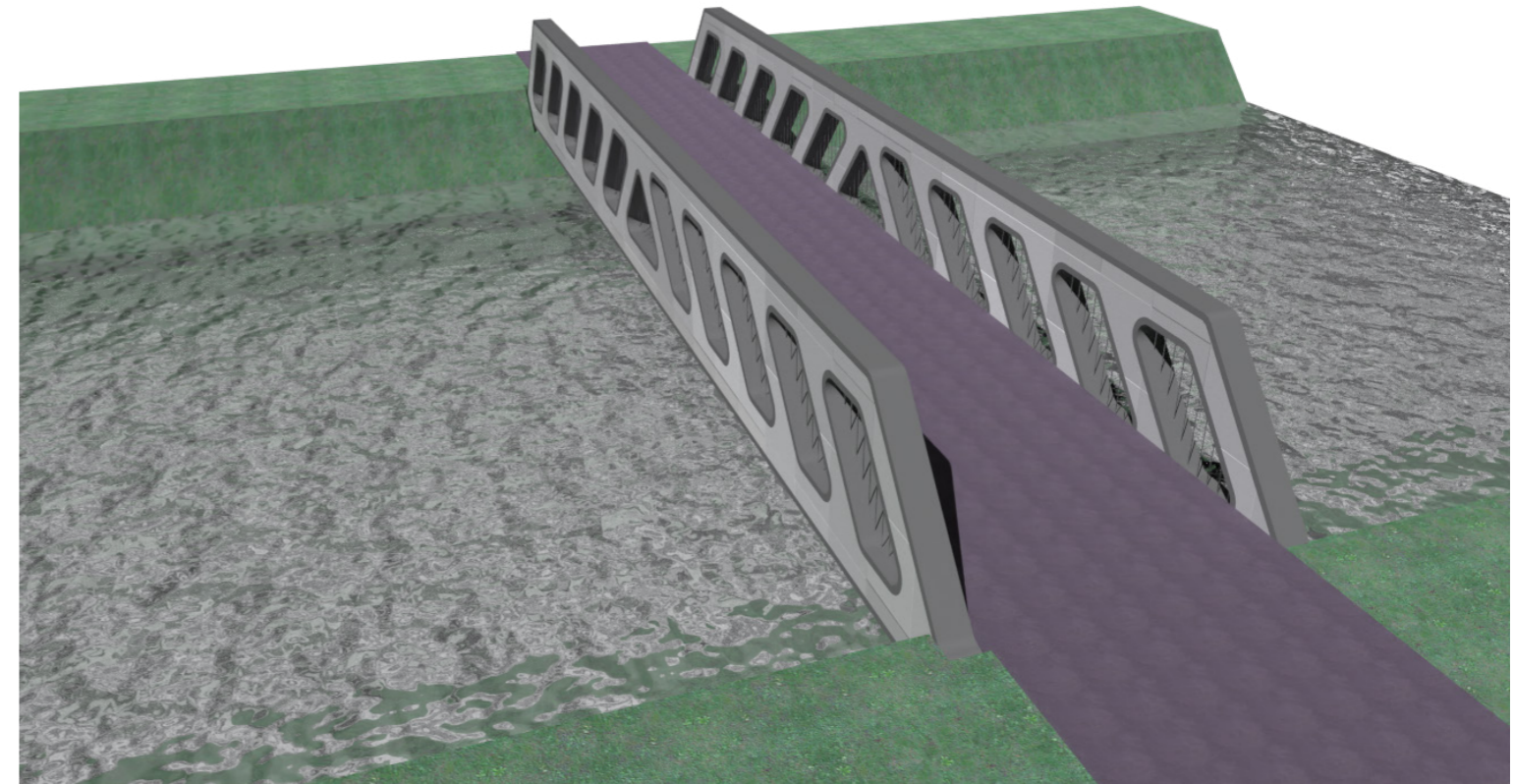

### step 8: finishes

The path surfacing is added (by others) and the bridge reaches final completion.

minimass™